

SUPERIOR DEEP CYCLE AGM BATTERY

AMX6-245 (6V245Ah)



CHARACTERISTICS

Item	Specifications	
Voltage	6V	
Dimension	Length	243mm (9.57inches)
	Width	187.5mm (7.38inches)
	Container Height	275mm (10.8inches)
	Total Height	275mm (10.8inches)
Approx Weight	32.4kg (71.4lbs)	
Terminal	T11(M8)	
Container Material	ABS	
Reserve Capacity	25A	530min
	56A	206min
	75A	145min
Capacity	20HR	245Ah
	10HR	232Ah
	5HR	210Ah
Operating Temp. Range	Discharge	-20~55°C (-4~131°F)
	Charge	0~40°C (32~104°F)
	Storage	-15~40°C (5~104°F)

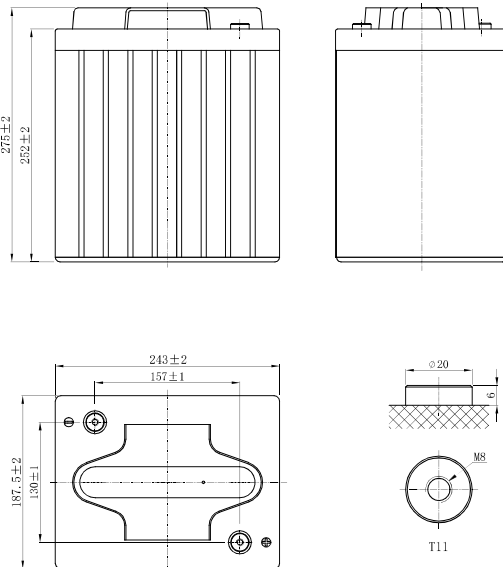

APPLICATIONS

- Electric vehicle
- Golf cart
- Sightseeing
- Cleaning equipment
- AWP
- Mobility



Note: Terminal Torque Values in-lb(Nm):97.28-130.0(11.0-14.7)

Auramax Fzc.

www.aura-max.com

SUPERIOR DEEP CYCLE AGM BATTERY

AMX6-245 (6V245Ah)



GENERAL FEATURES

Stable initial capacity

- PAM/NAM amount optimization
- 4BS crystal paste mixing & curing technology
- Double layer separator technology
- Improved design electrolyte S.G.

Less water loss

- PAM/NAM amount optimization
- New PAM/NAM recipe introduced
- Rare earth alloy

Solve NAM sulphation

- Carbon boost technology
- Pre-sulfate technology

Improved PSoC cycling

- Carbon boost technology
- Mix carbon boost technology
- Targeting for higher level through carbon technology

Delay PAM softening and shedding

- Plate assembly pressure re-engineering
- 4BS crystal paste mixing & curing technology
- Higher paste density

Optimize electrolyte stratification

- Introduce AGM-GEL technology

Excellent deep cycle performance

- Plate assembly pressure re-engineering
- New PAM/NAM recipe introduced
- Gel electrolyte technology
- Rare earth alloy
- Double layer separator technology
- Lower acid filling temperature

